

The Surplus 10 MHz Rubidium Frequency Standard LPRO-101 by DATUM/EFRATOM in the ham shack

Hans, DL2MDQ and Juergen, DD6UJS, 20.10.09

Introduction: The compact 10 MHz Rb atomic clock module LPRO-101 from Datum/Efratom which is cheaply available on the surplus market has been integrated into an aluminium cabinet together with the necessary 24 V power supply, a converter stage to TTL and a subsequent fast driver.

The system built up has a sine wave output delivering 6 dBm in maximum into 50 Ohm for frequency calibration purposes and has also a 50 Ohm TTL output which can be used as a reference for a frequency counter system. Figures 1 and 2 give an impression of the size of the unit and how it has been integrated. Purchase of the unit was stimulated by the QEX article by John, KOIZ, (7), and the effort to condense our experience in a paper by the recent QEX article by Bob, KE6F (8). Our system differs by those described in the QEX articles only by the TTL-converter added.



Fig.1: The closed aluminium cabinet with the Rubidium frequency standard LPRO-101 , a 24V switching power supply and a sine to TTL converter built in.

Mechanics and electronics:

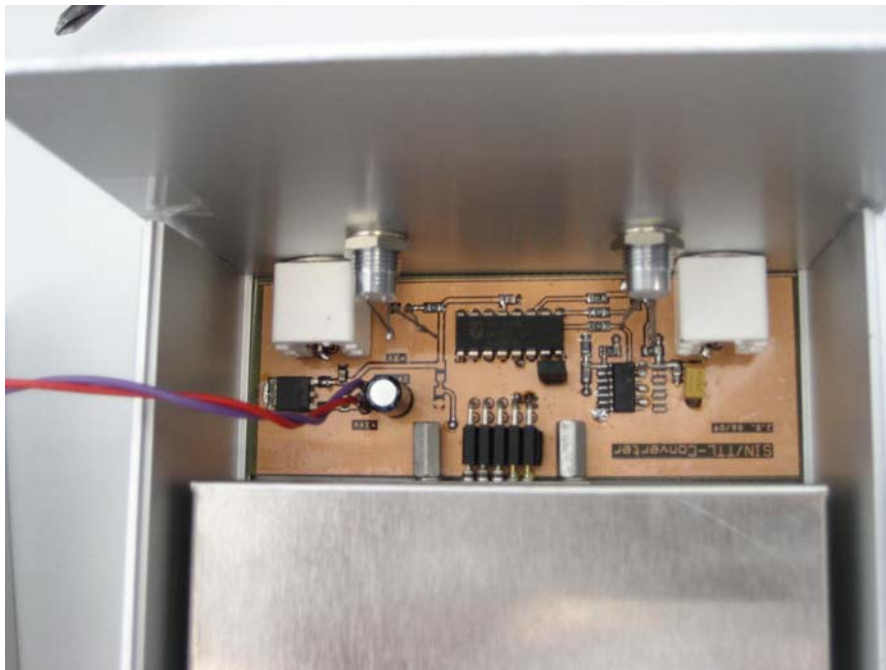
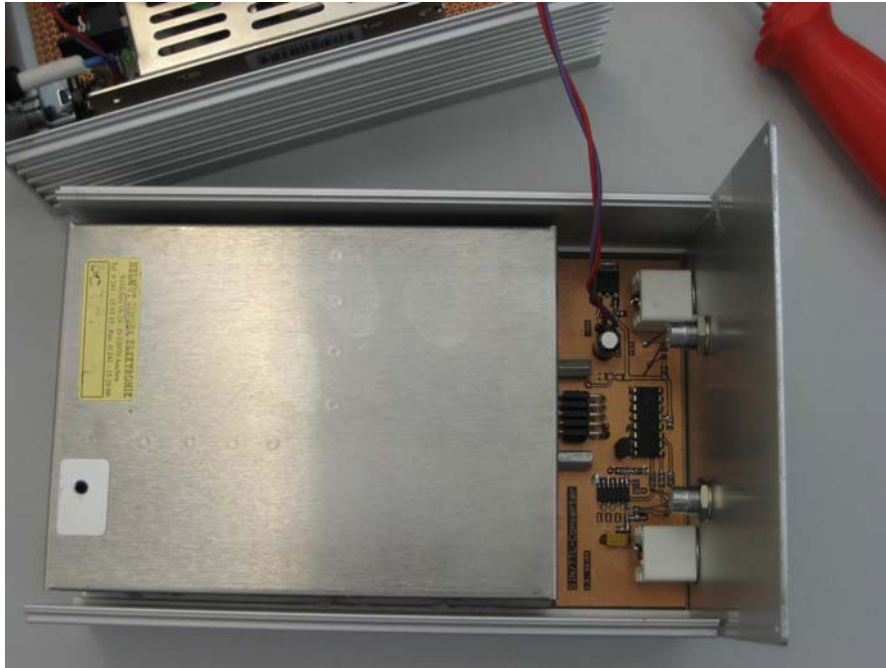

Figs.2: The upper photo shows the cabinet with its upper part containing the power supply removed showing the LPRO-unit with its metal shielding. All connections are via the small connector on the right side in the middle.

The lower photo shows in more detail the small printboard developed providing the power connection to the LPRO-unit carrying also the TTL converter; Sine and TTL output signals are available on the BNC connectors left and right. The circuit is given in Fig.3 and described in the text below.

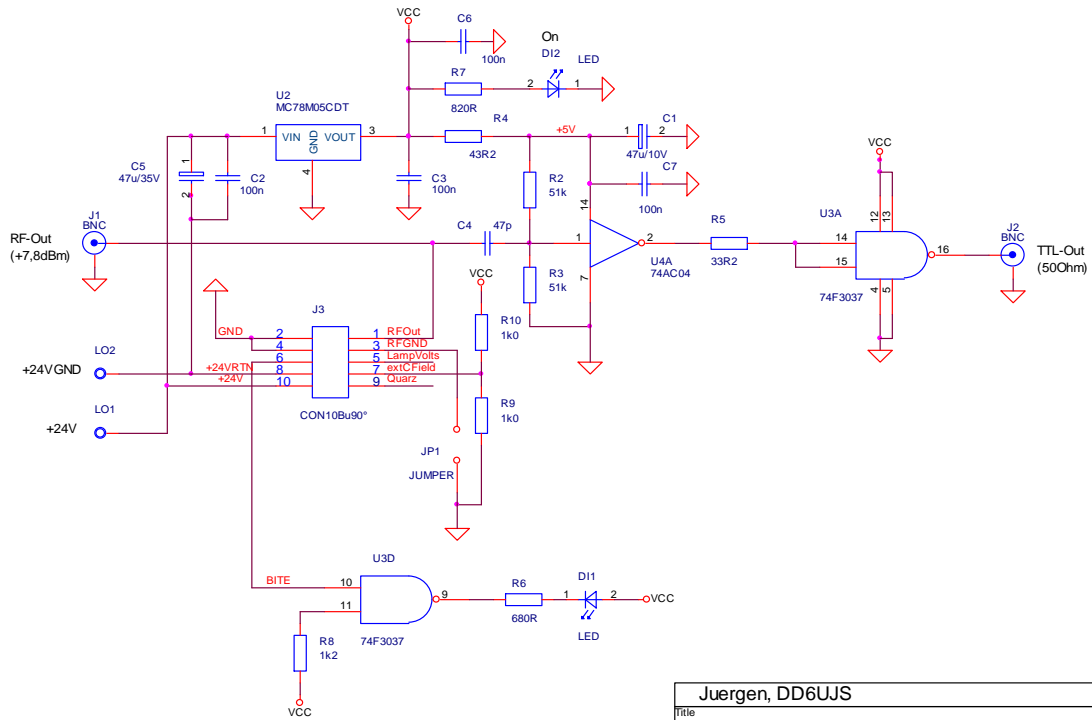

Juergen, DD6UJS		
Title		
Sinus/TTL-Converter, low phase noise		
Size	Document Number	Rev
A	sintticonv.dsn	1.1
Date:	Monday, June 29, 2009	Sheet 1 of 1

Fig.3: The figure gives the circuit added to supply the LPRO-101 unit with 24 V via the connector J3 and to drive LED D11 via U3D to show the lock situation of the unit. The other components are used as a sine-to-TTL-converter, ICs U4A and U3A, and the corresponding regulator U2. The circuit is similar to what is proposed in the LPRO-101 Manual (6).

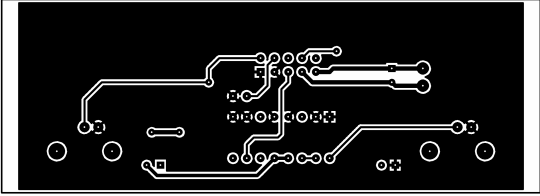
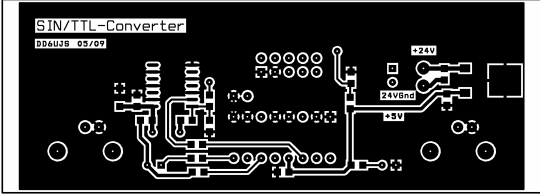
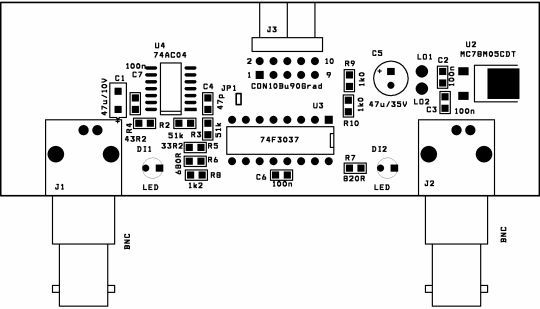

Fig.4: The small printboard carrying the circuit given in Fig.3.

Physics background: Before test measurements are being described, the physics background should briefly be outlined. We refer to the old articles from the late fifties and sixties, the time when the atomic standards have been developed (1, 2, 3, 4, 5) and describe the physics mechanisms as discussed in these papers as well as the overall realization in the LPRO-101.

In Rubidium (Rb) as in other atomic clock systems using Hydrogen or Caesium, the hyperfine transition of the atomic ground state, typically in the GHz range of frequencies, is being used to phase lock a quartz oscillator delivering the output signal. In the LPRO-system a method called optical pumping is being applied rather than measuring directly the absorption of Rb-vapour in a gas cell at the transition frequency between the two hyperfine energy levels of the Rb ground state at 6.834684 GHz. The optical pumping method has the advantage that a kind of internal energy amplification is then present clearly improving the signal-to-noise-ratio (see below).

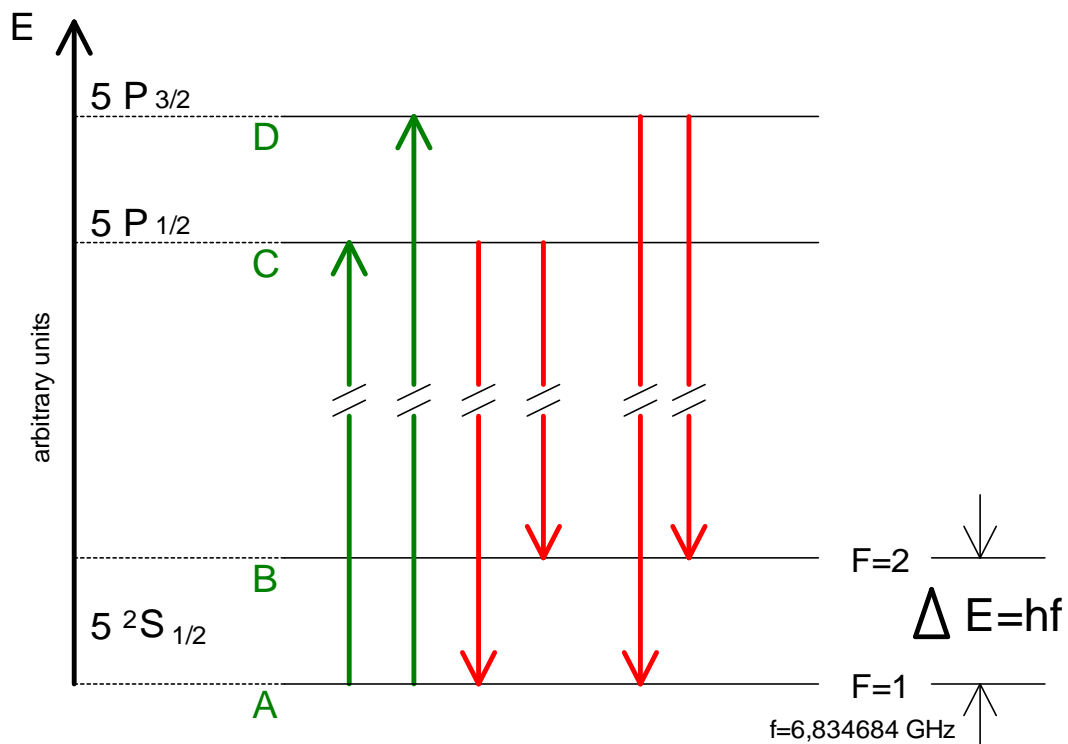

Fig.5: Atoms have discrete energy states which are usually given in a form as shown in this figure. The vertical scale is the energy scale. Upward transitions between states occur after absorption of electromagnetic radiation, correspondingly downward transitions are connected with the emission of radiation. The frequency of absorbed or emitted radiation is proportional to the energy difference of the energy levels involved.

The figure gives the energy level diagram of the Rubidium atom. Only those levels important for the understanding of the physical processes are given. They are not given to scale, in particular the energy difference of the hyperfine levels $F=1$ and $F=2$ is largely increased. On the left the physics labelling of the energy levels of the Rb-atom are given. The principal quantum number is 5. P and S characterize the total angular momentum of the $n=5$ electron, while $\frac{1}{2}$ and $\frac{3}{2}$ at the lower right give their total angular momentum including the electron spin. The number F results from considering in addition the nuclear spin. To avoid physics details, we count the various energy levels involved just by A, B, C, and D for simplicity.

Figure 5 gives the energy level diagram of Rubidium (see figure caption for more details). The hyperfine transition mentioned is the transition between the $F=2$ and the $F=1$ levels of the Rb-atom ground state, in physicist's nomenclature called a $5^2S_{1/2}$ state. These two levels correspond to the combination of the electron and the nuclear spins being parallel in the $F=2$ and anti-parallel in the $F=1$ state.

The transition is being called a spin flip transition. It can be induced by the application of an rf-field at proper frequency $f = 6.834684$ GHz, so that the product hf corresponds to the energy difference $\Delta E = hf$ of the two states, the constant h being Planck's constant, $h = 6.626 \cdot 10^{-34}$ Js.

In case Rb-atoms are brought into a radio frequency field of exactly this frequency, the magnetic component of the rf-field induces transitions both upward and downward i.e. from the lowest state $F=1$ to the next higher state $F=2$ meaning upwards and vice versa downwards. In case there is no difference in the number of atoms in the two states no net absorption of the rf-field will take place. This means that under the influence of the rf-field equal numbers of atoms are changing their state per second by going upwards (absorption) or by going downwards (stimulated emission). At room temperature and higher there is almost no difference in the numbers of atoms in the two states (Boltzmann factor ≈ 1). So no net effect is expected under these conditions, this means the mere application of a radio frequency field is not enough to allow the observation of any effect unless there is an inequality in the populations of the levels involved.

An unbalance in the number of atoms in states $F=1$ and $F=2$ is established, however, by the process called optical pumping. In this process line radiation in the near infrared (IR) at wavelengths 794.7 and 780.0 nm respectively from a Rb-lamp and properly filtered by a gaseous filter cell filled with the Rb isotope ^{85}Rb causes transitions mainly from the $F=1$ ground state of the ^{87}Rb vapour in the resonance cell (1). These transitions are given in green in the level diagram in figure 5 with arrows indicating the absorptive upward transition into the higher energy levels C and D of the Rb-atom. Atoms raised from the $F=1$ state (A) into the so-called P-states (labelled C and D in figure 5) will emit IR-radiation after a very short time when the Rb-atoms excited in this way relax by going back with equal probability into the atomic ground states $F=1$ and $F=2$ (A and B in figure 5). These transitions are marked in red in Fig.5.

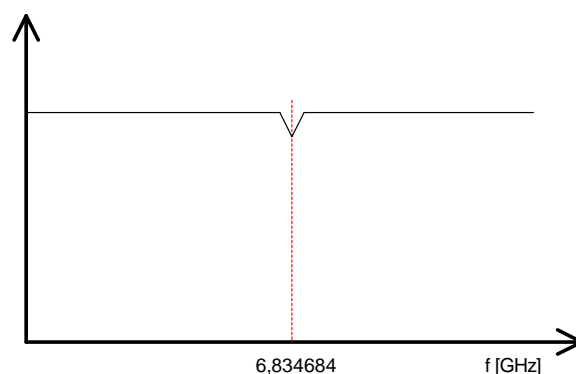

Fig.6: The sketch gives the photocell signal as function of frequency applied to the Rb gas cell. In case the frequency f exactly corresponds to the hyperfine transition the absorption increases as explained in the text. An electronic control loop keeps the frequency locked to the dip (Fig.7). The dip is not deeper than about 1%.

Since due to the proper preparation of the lamp radiation, pumping into higher states takes place mainly from the lower $F=1$ state (A), the occupation number of the $F=1$ state as physicists say i.e. the number of atoms in that state, becomes smaller under steady state conditions during the illumination by the Rb-lamp compared to the $F=2$ state (B).

If now the microwave rf-field at the transition frequency 6.834684 GHz is being applied, more microwave transitions from $F=2$ to $F=1$ than vice versa are induced since more atoms are present in the upper $F=2$ state and less in the lower $F=1$ state due to the optical pumping process. The application of the rf-field then increases the number of atoms in the lower $F=1$ state.

As a result the absorption of the light from the Rb-lamp increases but only if the frequency of the rf-field applied exactly corresponds to the transition between the two hyperfine energy levels,

$f=6.834684$ GHz. The absorbed IR-light is measured by a photo-detector. In case the right frequency is applied, the photo detector signal drops slightly as sketched in Fig.6.

LPRO set-up: In the LPRO101-Rb frequency standard the frequency f is deduced in a complicated multiplier and mixing scheme from a 20 MHz voltage controlled quartz oscillator VCXO. This occurs in the block SYNTH. in figure 7. The 20 MHz signal is split into two paths. In the first the signal is multiplied by a factor of 3 then by a factor of 114 resulting in $f_{\text{VCXO}} \times 3 \times 114 = 6.840$ GHz. In the second path it is multiplied by 17 and divided by 64 resulting in $f_{\text{VCXO}} \times 17/64 = 5.3125$ MHz. The two signals are then mixed to give the difference frequency $6.84 \text{ GHz} - 5.3125 \text{ MHz} = 6.834688$ GHz. To overcome the still existing small difference to the Rb resonance frequency, a weak magnetic field is applied to the Rb gas cell shifting the energy levels of the $F=1$ and $F=2$ states such that their difference equals Planck's constant h times the synthesized frequency, $\Delta E = h \cdot 6.834688 \text{ GHz}$.

The VCXO is controlled such that a maximum of absorption of the IR-line from the Rb-lamp radiation occurs. The oscillator is locked to this absorption maximum corresponding to the dip shown in Fig.6.

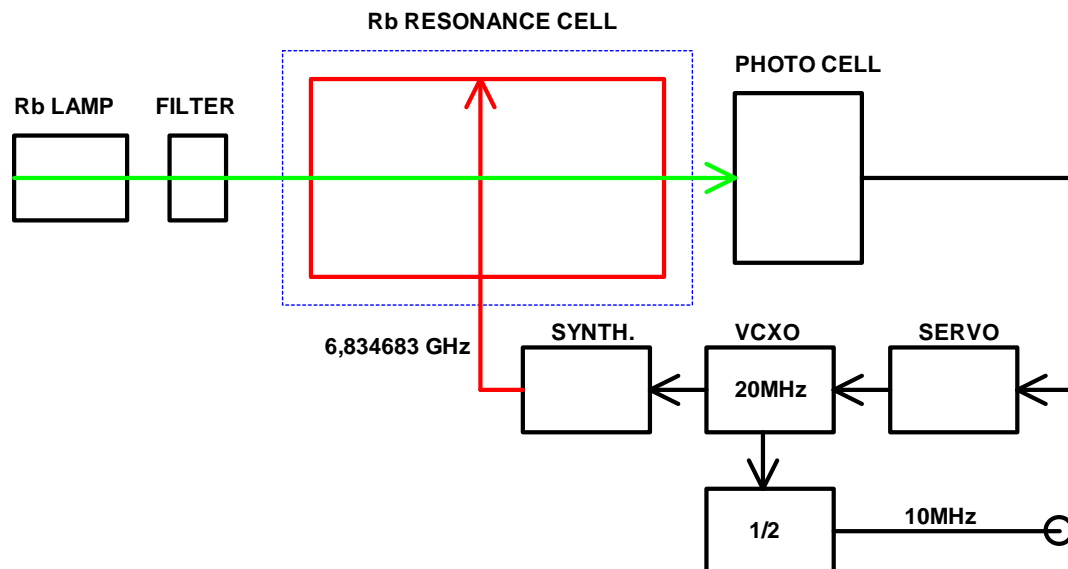

Fig.7: The figure gives the block diagram of the overall arrangement. The Rb gas cell is illuminated by the filtered light from a ^{85}Rb lamp. A photo cell measures the light passing the gas cell filled with ^{87}Rb atoms (green horizontal arrow). Simultaneously the microwave signal is applied (red vertical arrow). At the frequency of the hyperfine transition the light absorption in the cell increases. A servo loop controls the frequency of the microwave signal at maximum absorption making use of the high accuracy of this transition frequency in the Rb-atom. The frequency $f=6.834683$ GHz is derived in a complicated multiplier and mixing scheme from a 20 MHz VCXO at 20 MHz. Its frequency is kept constant at an accuracy determined by the transition frequency of the Rb-atom. For details of the synthesizer scheme see the LPRO-101 Manual (6).

The manual says: „The dip in the photo detector current is used to generate a control signal with phase and amplitude information, which permits continuous regulation of the VCXO frequency. The servo section converts the photo detector current into a voltage, then amplifies, demodulates, and integrates it for high dc servo loop gain“ (6).

Qualitatively it is accomplished by frequency modulating the synthesized microwave signal irradiating the gas cell by some 10^{-8} relative frequency sweep. This has the consequence that the absorption dip is periodically cycled resulting in a modulated photo detector signal with an AC component at the modulation frequency. Together with the modulating signal it is forming the input of a phase locked loop locking the VCXO to the zero crossing of the AC photodetector signal.

The absorption in the near IR region as generated by the Rb-lamp can be measured with a photo cell with much higher significance than the very small energy absorption out of the rf-field due to the higher quantum energies involved (factor more than 5000). This is what was called before the internal energy amplification process causing much improved S/N in the measurement of the absorption dip, and this is the reason why the optical pumping process is introduced.

Test measurements: Tests of the frequency accuracy of the surplus LPRO unit have been conducted by measuring the beat frequency respectively the beat period with a signal supplied by a modern commercial 10 MHz Rb frequency standard locked to GPS. Both output signals of the units to be compared are applied to an oscilloscope. Figure 8 gives the overall set-up while figure 9 gives a closer look to the oscilloscope's screen. The TTL-signal from the surplus unit is used (yellow) while the sine output of the reference standard (blue) is fed to a second input channel of the oscilloscope and is used as well to trigger the scope.

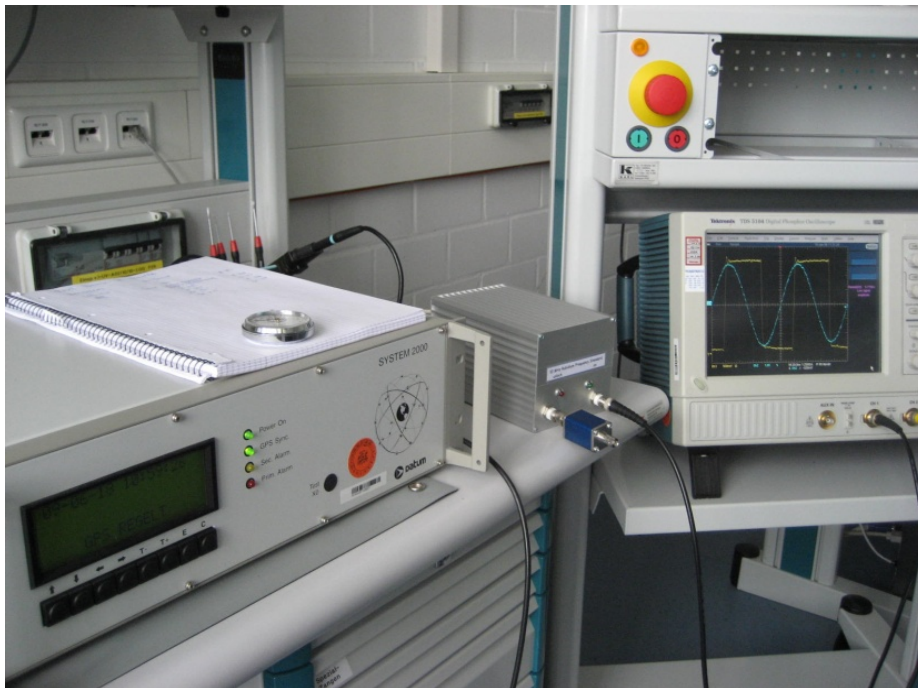

Fig.8: Test set-up comparing the 10 MHz signal from a GPS locked Rb-standard (left) with the signal delivered by the surplus unit described before (centre). Both signals are applied to an oscilloscope to compare frequencies by measuring their beat period.

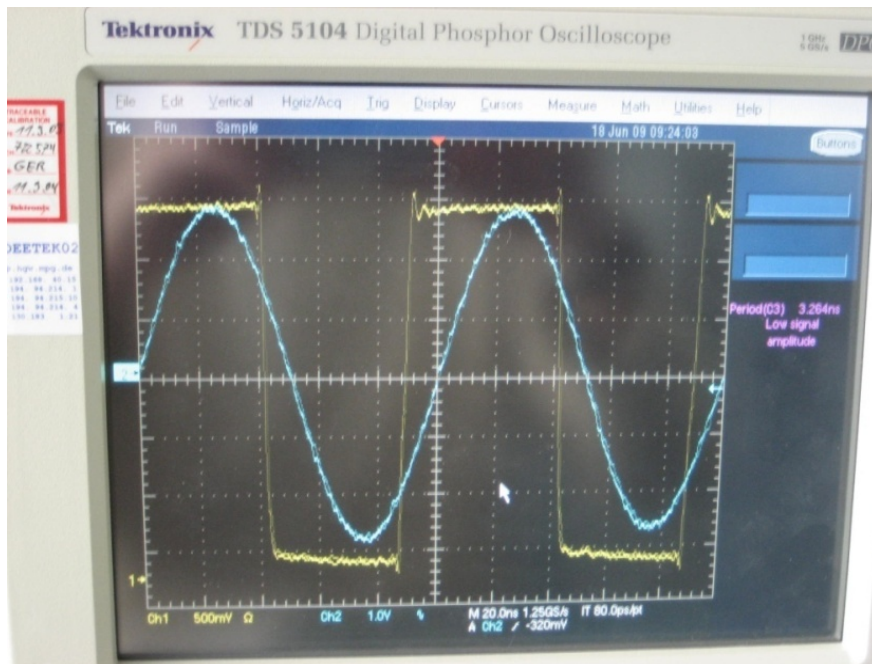

Fig.9: The two signals from the reference 10 MHz standard (blue) and the LPRO unit (yellow) are applied to an oscilloscope. The horizontal scale is 20ns per division. The sine wave is used to trigger the scope. The frequency deviation between the two signals is causing a time dependent phase shift between the two. By measuring the time for a 360 degrees phase shift the frequency deviation can be quantified. Typically almost 1000 seconds are measured for 360 degrees.

Since frequencies of the two devices to be compared are not exactly the same, the rectangular signal is drifting against the sine reference on the screen. The time necessary to shift by one period can be used as a measure of the frequency accuracy. It is found that after a warm-up period of about 20 minutes the time necessary for one period shift is almost 1000 seconds (Fig.10). This means that the deviation of the surplus unit is only about 10^{-3} Hz at a frequency of 10 MHz.

Assuming the GPS locked reference generator accurate to the order of 10^{-12} , the LPRO unit has a relative accuracy of almost 10^{-10} . For a more thorough analysis of the accuracy, see reference (8). This accuracy provided is by far good enough to check the accuracy of other ham shack equipment.

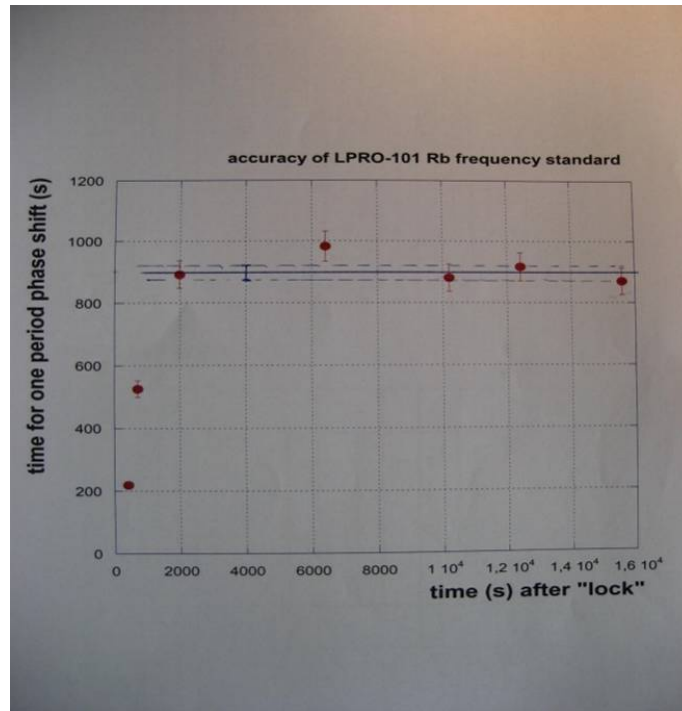

Fig.10: To quantify the frequency accuracy of the LPRO surplus standard, its frequency has been compared with the frequency supplied by a modern commercial GPS locked Rb-standard. The comparison has been conducted by measuring the time needed for a 360 degrees phase shift between the two signals (see text for more details). The longer the time, the smaller the frequency deviation. A number of measurements have been done after switching on the LPRO unit given as red dots in the figure. After about 20 minutes the time needed approaches almost 1000 seconds, corresponding to a deviation of about 1/1000 Hz at 10 MHz.

One first application was the comparison with an OCXO oscillator used as the clock source in a hpSDR system consisting of Mercury, Penelope, Ozymandias, and Atlas provided by TAPR (9). Instead of using the internal 10 MHz sources on the Mercury or the Penelope boards an external OCXO source has been built up using an OCXO purchased by the German Axtal company (figure 11). Another external accurate source will soon be provided by TAPR called Excalibur (10).

The PowerSDR software used to run the hpSDR system can easily be used to check the frequency deviation by applying the LPRO signal to the receiver and watching the phase difference in DSB reception mode (figure 12). Again the time was measured for a 360 degrees phase shift. It was found that this time is about 100 seconds corresponding to a deviation of 1/100 Hz compared to the surplus Rb-standard. At 10 MHz this corresponds to a relative accuracy of a few 10^{-9} .

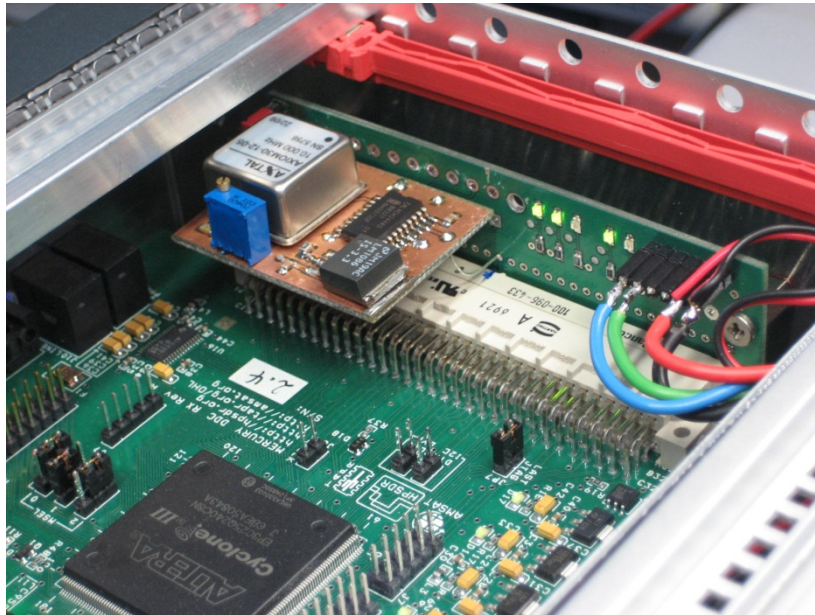

Fig.11: The photo shows the Axtal 10 MHz OCXO mounted on a small printboard connected to the Atlas board of the hpSDR transceiver (9). It is used as the clock source in this fully digital transceiver system and determines its frequency accuracy and stability.

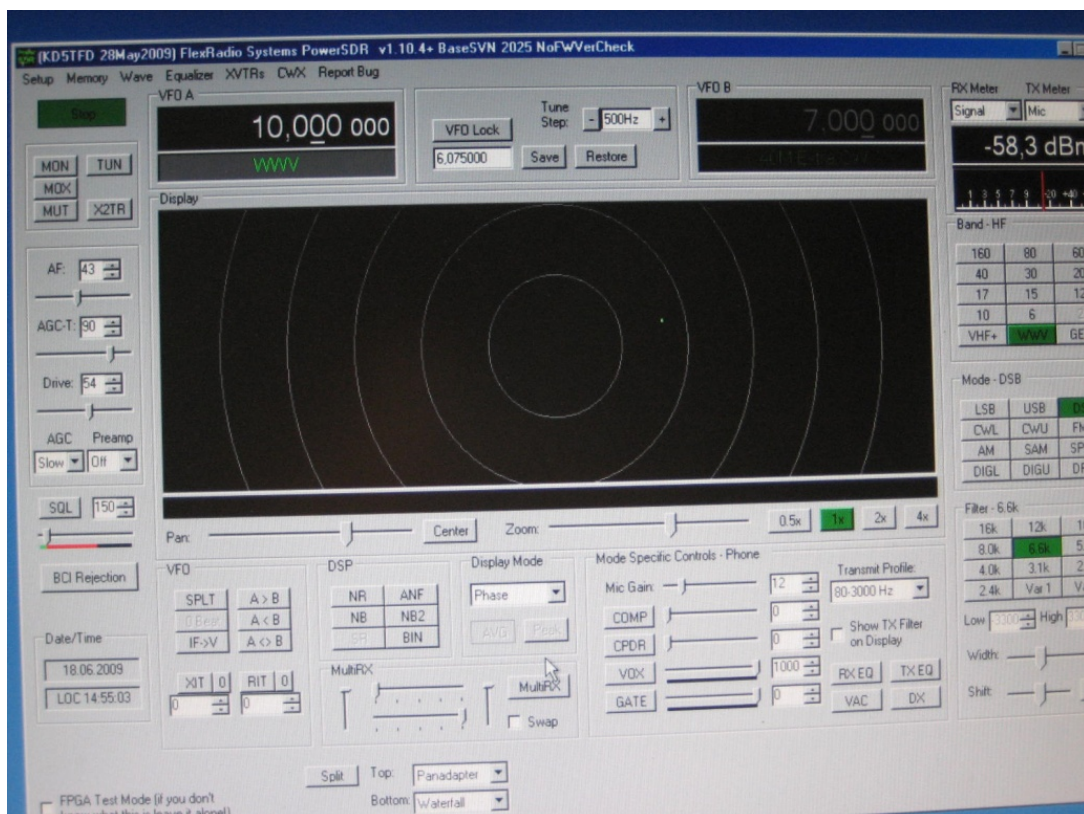

Fig.12: The frequency offset between the ham shack LPRO 10 MHz standard and the 10 MHz clock source used in the hpSDR transceiver can easily be measured applying basically the same method as described before, by measuring the time needed for a 360 degrees phase shift. The screen shot gives a polar presentation of the phase, the small green dot between the inner two circles showing the phase wandering around. About 100 seconds are measured for one turnaround corresponding to 1/100 Hz deviation at 10 MHz.

References

- 1 P.L. Bender et al, Phys. Rev. Lett. **1**, 311 (1958)
- 2 M. Arditi, T.R. Carver, Phys. Rev. **124**, 800 (1961)
- 3 V.B. Gerard, Brit. J. Appl. Phys. **13**, 409 (1962)
- 4 M.E. Packard, B.E. Swartz, IRE Trans. Instrum. p. 215, Dec. 1962
- 5 J.C.Camparo, R.P. Frueholz, J. Appl. Phys. **59**, 3313 (1986)
- 6 <http://www.ham-radio.com/sbms/LPRO-101.pdf>
- 7 J.S. Raydo, QEX **245**, 49 (2007)
- 8 B. Miller, QEX **256**, 35 (2009)
- 9 <http://openhpsdr.org/>
- 10 <http://openhpsdr.org/excalibur.html>